

LIGHT

1.1 LIGHT :

Light is a form of electromagnetic energy that causes the sensation of vision.

Optics :

It is the branch of physics which deals with the study of light. It is mainly divided into three parts :

(i) **Geometrical optical or ray options:** It deals with the reflection or refraction.

(ii) **Wave or physical optics:** It is concerned with nature of light and deals with interference diffraction and polarisation.

(iii) **Quantum optics :** It deals with the interaction of light with the atomic entities of matter such as photo electric effect, Atomic excitation etc.

1.1 (a) Nature of Light :

Theories about nature of light :

(i) **Particle nature of light (Newton's corpuscular theory):** According to Newton light travels in

space with a great speed as a stream of very small particles called corpuscles.

This theory was failed to explain interference of light and diffraction of light. So wave theory of light was discovered.

(ii) **Wave nature of light :** light waves are electromagnetic waves so there is no need of medium for the propagation of these waves. They can travel in vacuum also. The speed of these waves in air or in vacuum in maximum i.e., 3×10^8 m/s

(iii) **Quantum theory of light :** When light falls on the surface of metals like caesium, potassium etc, electrons are given out. These electrons are called 'photo-electrons' and phenomenon is called 'photo-electric effect.'

This was explained by Einstein. According to Planck light consisted of packets or quantas of energy called photons. The rest mass of photon is zero. Each quanta carries energy $E = hv$.

h → Planck's constant = 6.6×10^{-34} J-s.

v → frequency of light

$$\text{Einstein's photo-electric equation } h(v - v_0) = \frac{1}{2} m v_{\max}^2 .$$

hv_0 = amount of energy spent in ejecting and electron out of metal surface.

V_{\max} = maximum velocity of the ejected electron.

Some phenomenon's like interference of light, diffraction of light are explained with the help of wave theory but wave theory was failed to explain the photo electric effect of light. It was explained with the help of quantum theory. So, light has dual nature.

(i) Wave nature

(ii) Particle nature

1.1 (b) Source of Light :

A body which emits light in all directions is said to be the source of light. The source can be point one or an extended one. The sources of light ware of two types :

(i) **Luminous source** : Any object which by itself emits light is called as a luminous source. Eg. Sun and stars (natural Luminous sources), electric lamps, candles and lanterns (artificial luminous sources).

when (ii) **Non-luminous source** : Those objects which do not emit light but become visible only light from luminous objects falls on them. They are called non-luminous. Eg. Moon, planets (natural non-luminous sources), wood, table (artificial non-luminous sources).

10.1 (c) Medium of Light :

Substance through which light propagates or tends to propagate is called medium of light.

(i) **Transparent object** : Bodies that allow light to pass through them i.e. transmit light through them, are called transparent bodies. Eg. Glass, water, air etc.

(ii) **Translucent object** : Bodies that can transmit only a part of light through them are called translucent objects. Eg. Froasted or ground glass, greased paper, paraffin wax.

(iii) **Opaque object** : Bodies that do not allow light to pass through them at all are said to be opaque object, Eg. chair, desk etc.

1.1 (d) Rectilinear Propagation of Light :

Light travels in a strength line. In vacuum or air light travels with the velocity of 3×10^8 m/s

1.1 (e) Behaviour of Light at the Interface of Two Media :

When light traveling in one medium falls on the surface of a second medium the following three effects may occur :

(i) A part of the incident light is turned back into the first medium. This is called reflection of light.

(ii) A part of the incident light is transmitted into the second medium along a changed direction. This is called refraction of light.

(iii) The remaining third part of light energy is absorbed by the second medium. This is called absorption of light.

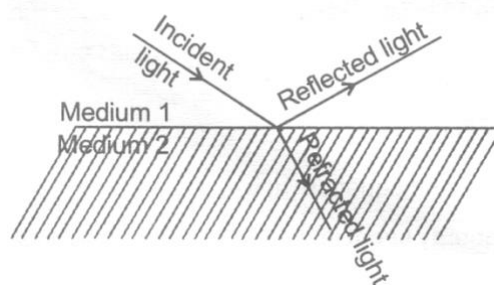

1.2 REFLECTION OF LIGHT :

When a beam of light falls on any surface, a part of it is sent back into the same medium from which it is coming. This phenomenon is known as the reflection of light.

- (i) The ray of light which falls on the mirror surface is called the incident ray. The angle of incidence is the angle made by the incident ray with the normal at the point of incidence.
- (ii) The ray of light which is sent back from the mirror is called the reflected ray. The angle of reflection is the angle made by the reflected ray with the normal at the point of incidence.
- (iii) The normal is a line at right angle to the mirror surface at the point of incidence.

1.2 (a) Laws of reflection :

- (i) Incident ray, normal ray and the reflected ray all lie on the same plane.
- (ii) The angle of incidence is always equal to the angle of reflection.

Q. What happens when a ray of light falls normally (or perpendicularly) on the surface of a mirror ?

Ans. A ray of light which is incident normally on a mirror, is reflected back along the same path because the angle of incidence as well as angle of reflection for such a ray of light are zero.

1.2 (b) Type of reflection :

- (i) **Regular reflection** : When a parallel beam of light is incident on a plane highly polished surface, the reflected beam will also be parallel and hence the whole light falling on the surface is reflected in a definite direction. Such a reflection is called regular reflection.



- (ii) **Irregular reflection** : When a parallel beam of light is incident on a rough surface or irregular surface, the rays get reflected in all directions and the reflected light spreads over a wide area.

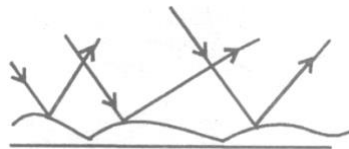

1.3 MIRROR :

It is a highly polished surface, which is quite smooth and capable of **reflecting** a good fraction of light from its surface.

1.3 (a) Object :

Anything which gives out light rays (either its own or reflected) is called an object.

- (i) **Real object** : All physical objects and light sources are real which either scatter light rays or produce light rays.

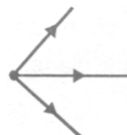

- (ii) **Virtual object** : When converging incident rays incident on eye or an optical device, there is no signal point from which light rays appear to be coming. In this case we say object is virtual.

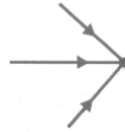

1.3 (b) Image :

The reproduction of object formed by mirror or lens is called an image.

- (i) **Real image** : An image which is formed by actual convergence of the rays of light is called real image.
- (ii) **Virtual image** : An image which only appears to the eye to be formed by the rays of light is called virtual image. It cannot be obtained on a screen.

1.3 (c) Types of mirror :

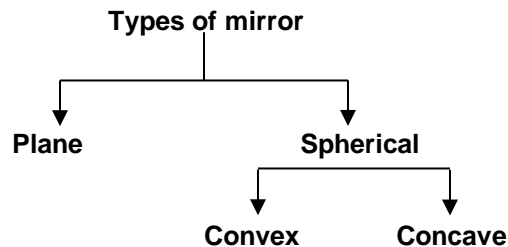

1.4 SPHERICAL MIRRORS :

A mirror whose reflecting surface is a part of a hollow of glass is known as spherical mirror. For example, a dentist uses a curved mirror to examine the teeth closely, large curved mirrors are used in telescopes at observatories. These are of the type convex and concave.

1.4 (a) Some terms related to spherical mirrors :

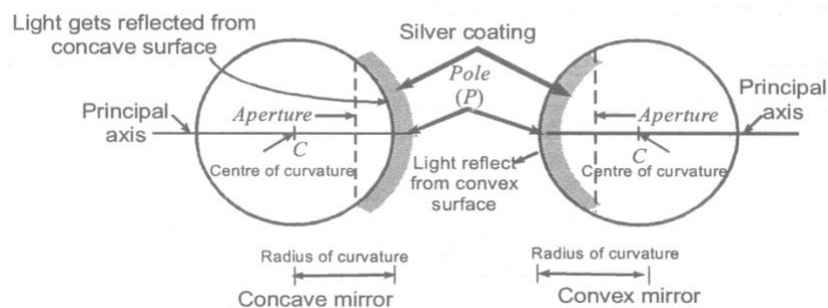

- (i) **Pole** : The central point of mirror is called it pole.
- (ii) **Centre of curvature** : The centre of the sphere of which the mirror is a part is called centre of curvature.
- (iii) **Radius of curvature** : The radius of the sphere of which the mirror is a part is called radius of curvature.
- (iv) **Principal axis** : The straight line joining the pole and the centre of curvature is called the principal axis.

(v) **Focal plane** : A plane passing through the principal focus and a right angles to the principal axis. of a spherical mirror is called the focal panel.

(vi) **Focal length** : The distance between the pole and the focus is called the focal length. The focal length is half the radius of curvature.

(vii) **Aperture** : The size of the mirror is calls its aperture.

(vii) **Principal focus** :

Focus of concave mirror	Focus of convex mirror
A parallel beam of light after reflection from a concave mirror converges at a point in front of the mirror. This point (F) is the focus of a concave mirror it is real.	A parallel beam of light after reflection from a convex surface diverges and the rays do not meet. However on producing backward, the rays appear to meet at a point behind the mirror. This point is focus of the convex mirror and it is virtual.

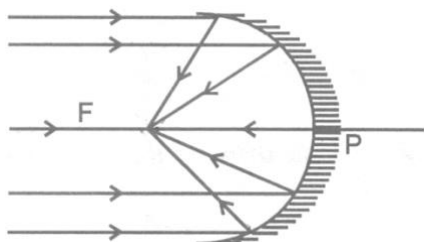

Focus of concave mirror

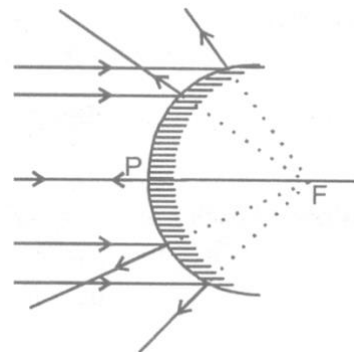

Focus of convex mirror

DAILY PRACTICE PROBLEMS # 1

OBJECTIVE DPP - 1.1

- The path along which light travels in a homogenous medium is called the :
 (A) beam of light (B) ray of light (C) pencil of light (D) none of these
- A thin layer of water is transparent but a very thick layer of water is :
 (A) translucent (B) opaque (C) most transparent (D) none of these
- Air is not visible because it _
 (A) is nearly a perfectly transparent substance
 (B) neither absorbs nor reflects light
 (C) transmits whole of light

(D) all the above are correct

4. According to laws of reflection of light :
- (A) Angle of incidence is equal to the angle of reflection
 - (B) Angle of incidence is less than the angle of reflection
 - (C) Angle of incidence is greater than the angle of reflection
 - (D) None of these

5. Which of the following correctly represents graphical relation between angle of incidence (i) and angle of reflection (r) ?

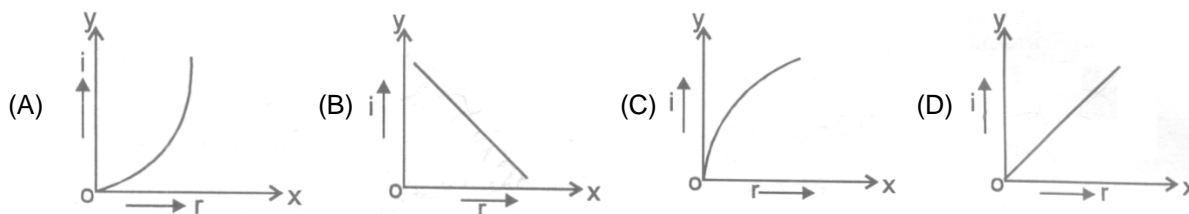

6. A convex mirror of focal length f (in air) is immersed in a liquid ($\mu = \frac{4}{3}$). The focal length of the mirror in liquid will be :

- (A) $\left(\frac{3}{4}\right) f$ (B) $\left(\frac{4}{3}\right) f$ (C) f (D) $\left(\frac{7}{3}\right) f$

7. A ray of light is incident on a plane mirror at an angle θ . If the angle between the incident and reflected rays is 80° , what is the value of θ :

- (A) 40° (B) 50° (C) 45° (D) 55°

8. When a ray of light enters a transparent medium it undergoes change is :

- (A) Frequency only (B) Wavelength only
(C) Wavelength and velocity both (D) Velocity and frequency both

SUBJECTIVE DPP - 1.2

1. According to given figure what angle does reflected rays from m_2 mirror will make with m_2 mirror ?

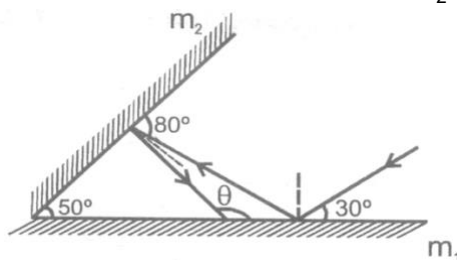

2. he mirrors are placed parallel to each other according to given figure. What will be the angle made by rays - with mirror M_1 , after third reflection in degree ?

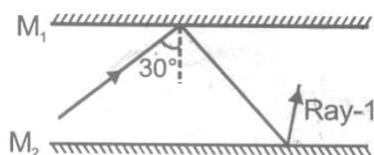

3. What are the value of angle of incidence and angle of reflection for normal incidence ?

➤➤➤ LIGHT ◀◀◀

PL - 2

2.1 CONCAVE AND CONVEX MIRROR :

Convex mirror is a spherical mirror, whose inner (cave type) surface is silvered and reflection takes place at

the outer (convex) surface.

Concave mirror is a spherical mirror, whose outer bulged surface is silvered and reflection takes place from

the inner hollow (cave type) surface.

2.1 (a) Rules for the formation of images by concave & convex mirrors :

- (i) A ray incident parallel to the principal axis actually passes (concave) or appears to pass (convex) through the focus.

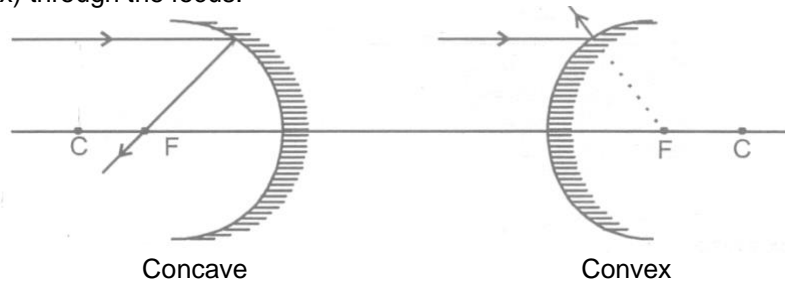

- (ii) A ray incident through the centre of curvature (C) falls normally and is reflected back along the same path.

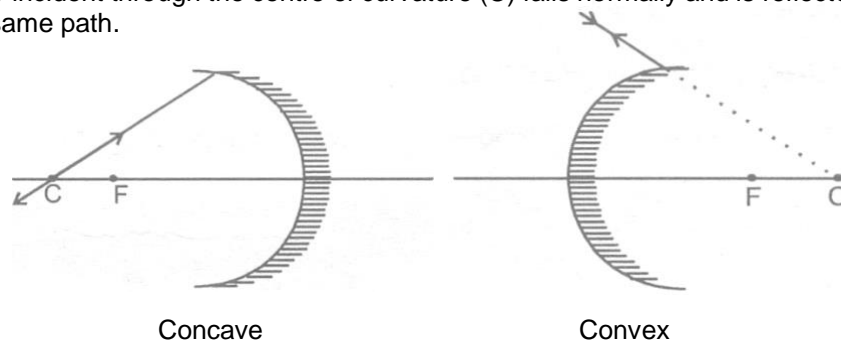

- (iii) A ray incident through the focus is reflected parallel to the principal axis.

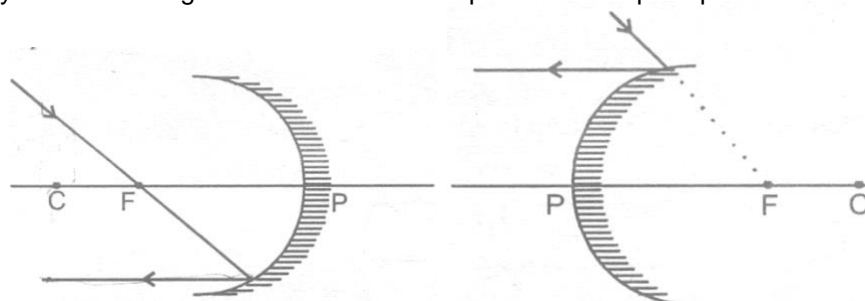

Concave

Convex

2.1 (b) Formation of image by convex mirror :

- (i) When the object is placed at infinity then image is formed at the focus. The image formed is virtual, erect and extremely demised.

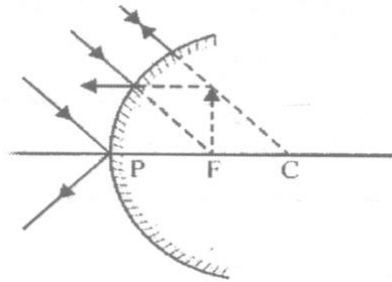

- (ii) When the object is placed between infinity and the pole then the image is formed between the focus and the pole. The image formed is virtual, erect and diminished.

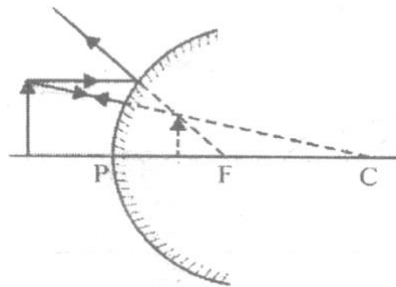

Uses of convex mirror :

Convex mirror is used as rear view mirror in automobiles like cars, trucks and buses to see the traffic at the back side.

2.1 (c) Formation of image by concave mirror

- (i) When the object is placed between the pole and the focus, then the image formed is virtual, erect and magnified.

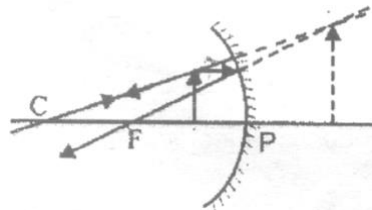

- (ii) When the object is placed at the focus then the image is formed at infinity. The image is externally magnified.

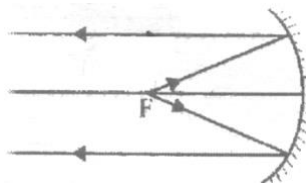

- (iii) When the object is placed between the focus and the centre of curvature then the image is formed beyond the centre of curvature. The image formed is real, inverted and bigger than the object.

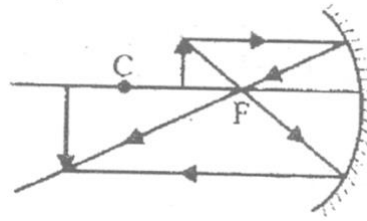

- (iv) When the object is placed at the centre of curvature, then the image is formed at the centre of curvature. The image formed is real, inverted and equal to the size of the object.

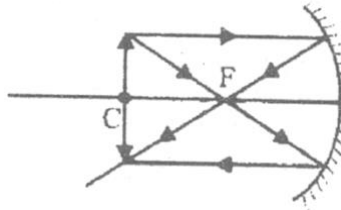

- (v) When the object is placed beyond the centre of curvature, then the image is formed between the focus and centre of curvature. The image formed is real, inverted and diminished.

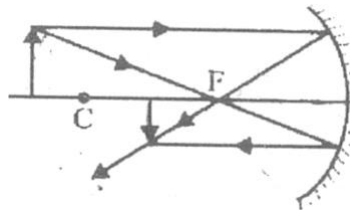

- (vi) When the object is placed at infinity then the image is formed at the focus. The image formed is real, inverted and extremely diminished in size.

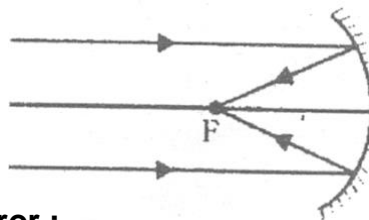

2.1 (D) Uses of concave mirror :

- (i) They are used as shaving mirrors.
- (ii) They are used as reflectors in car head-lights, search lights, torches and table lamps.
- (iii) They are used by doctors to concentrate light on body parts like ears and eyes which are to be examined.
- (iv) Large concave mirrors are used in the field of solar energy to focus sun-rays on the objects to be heated.

Q. How to distinguish between a plane mirror, a concave mirror and a convex mirror without touching them ?

Ans. We can distinguish between them by bringing our face close to each of them. All of them will produce different types of image of our face.

A plane mirror will produce an image of same size as our face. A concave mirror will produce a magnified image and our face will look much bigger. A convex mirror will produce a diminished image and our face will look small.

2.2 SIGN CONVENTION FOR MEASURING DISTANCE IN CONCAVE & CONVEX MIRROR :

- (i) All distances are measured from the pole.
- (ii) The incident ray is taken from left to right.
- (iii) Distances measured in the same direction as that of the incident ray are taken to be +ve.
- (iv) Distances measured in a direction opposite to the incident ray are taken to be -ve.
- (v) Distances measured upwards and perpendicular to principal axis are taken +ve.
- (vi) Distance measured downwards and perpendicular to principal axis are taken -ve.

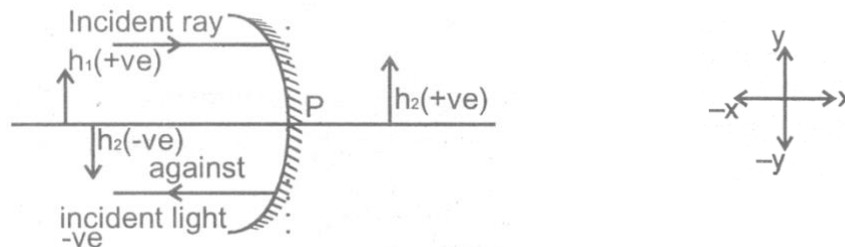

∴ { Focal length concave mirror is -ve }
 { Focal length of convex mirror is +ve }

IMPORTANT : These signs are according to the rectilinear co-ordinate system.

NOTE : Always draw a rough ray diagram while solving a numerical problem. Otherwise we will be confused.

as to which distance should be taken as +ve & which -ve.

For virtual image : M is +ve [as virtual image is erect ∴ h_2 is +ve as well as h_1 is +ve]

For real image : m is -ve [as real image is always inverted ∴ m is -ve while h_1 is +ve]

2.3 MIRROR FORMULA :

The mirror formula is a relation relating the object distance (u), the image distance (v) and the focal length (f) of a mirror.

The mirror formula is : $\frac{1}{u} + \frac{1}{v} = \frac{1}{f}$

2.4 POWER OF MIRROR :

A spherical mirror has infinite number of focus. Optical power of a mirror (in Dioptries) = - $\frac{1}{f(\text{in meters})}$

2.5 RELATION BETWEEN FOCAL LENGTH (f) AND RADIUS OF CURBATURE (R) :

$$R = 2f \text{ or } f = \frac{R}{2}$$

A curved or spherical mirror is reflecting surface, which is formed by a part of a hollow sphere. The spherical mirrors are of two types concave mirror and convex mirror.

2.6 MAGNIFICATION FOR CONCAVE MIRROR :

For magnification consider an object AB of height h_1 , placed beyond C, such that its one ray is incident at pole P & another passes through C. After reflection ray from pole comes in the direction PX and the one which passed through C after reflection meets PX at A'. So A'B' is the image of height h_2 .

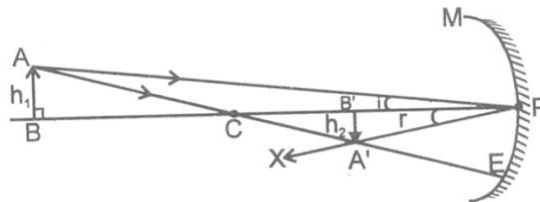

Now $\triangle ABP$ & $\triangle A'B'P$ are similar (By AAA)

$$\therefore \frac{A'B'}{AB} = \frac{B'P}{BP}$$

$$\frac{-h_2}{h_1} = \frac{-v}{-u} \Rightarrow \frac{h_2}{h_1} = -\frac{v}{u}$$

As $m = \frac{h_2}{h_1}$

$$\therefore m = -\frac{v}{u}$$

2.7 ILLUSTRATION :

(i) A 2.0 cm long object is placed perpendicular to the principal axis of a concave mirror. The distance of the object from the mirror is 30 cm and its image is formed 60 cm from the mirror on the same side of the mirror as the object. Find the height of the image formed.

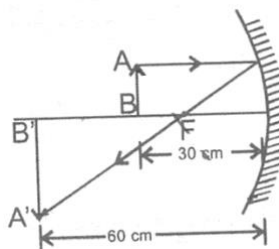

Sol. $u = -30 \text{ cm}$, $v = -60 \text{ cm}$

$$\therefore m = \frac{h_2}{h_1} = -\frac{v}{u} = -\frac{-60}{-30} = -2$$

$$\Rightarrow H_2 = -2h_1 = -2 \times 2 = -4 \text{ cm.}$$

\therefore Height of the image is 4 cm. It is inverted.

(iii) A 1.2 cm long pin is placed perpendicular to the principal axis of a convex mirror of focal length 12 cm, at a distance of 8 cm from it.

(a) Find the location of the image (b) Find the height of the image. (c) Is the image erect or inverted ?

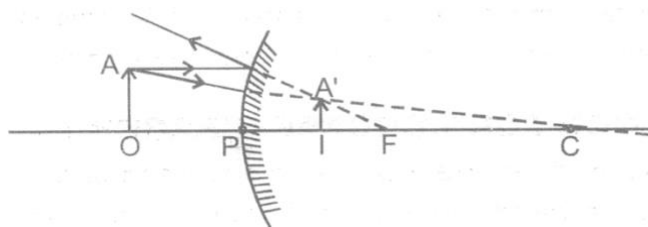

Sol. Here f is +ve so $f = 12$ cm.

Also $u = -8$ cm.

$$\therefore \frac{1}{v} + \frac{1}{u} = \frac{1}{f}$$

$$\text{Or } \frac{1}{v} = \frac{1}{f} - \frac{1}{u} = \frac{1}{12} + \frac{1}{8} = \frac{5}{24} \quad \therefore v = \frac{24}{5} \text{ cm} = 4.8 \text{ cm}$$

Given, $h_1 = 1.2$ cm

$$\text{We know } \frac{h_2}{h_1} = -\frac{v}{u} \quad \Rightarrow \quad h_2 = -\frac{v}{u} \times h_1 = 0.72 \text{ cm}$$

Image formed is erect.

DAILY PRACTICE PROBLEMS # 2

OBJECTIVE DPP-2.1

1. The image of the moon is formed by a concave mirror whose radius of curvature is 4.8 m at a time when distance from the moon is 2.4×10^8 m. If the diameter of the image is 2.2 cm the diameter of the moon is -
 (A) 1.1×10^6 m (B) 2.2×10^6 m (C) 2.2×10^8 m (D) 2.2×10^{10} m

2. The focal length of a concave mirror is f and the distance from the object to the principal focus is a . The magnitude of magnification obtained will be-
 (A) $(f + a)/f$ (B) f/a (C) \sqrt{f} / \sqrt{a} (D) f^2/a^2

3. The magnification of an object placed 10 cm from a convex mirror of radius of curvature 20 cm will be.
 (A) 0.2 (B) 0.5 (C) 1 (D) infinity

4. The image formed by a concave mirror is observed to be virtual, erect and larger than the object. the position of the object should be-
- (A) between the focus and the centre of curvature.
 (B) at the centre of curvature
 (C) beyond the centre of curvature
 (D) between the pole of the mirror and the focus
5. The magnification produces by a concave mirror-
- (A) is always more the one
 (B) is always less than one
 (C) is always equal to one
 (D) may be less than or greater than one
6. Choose the correct relation between u, v and R -
- (A) $R = \frac{2uv}{u+v}$ (B) $R = \frac{2}{u+v}$ (C) $R = \frac{2(u+v)}{(uv)}$ (D) none of these
7. The image formed by a concave mirror is real, inverted and of the same size as that of the object. The position of the object should be :
- (A) Beyond C (B) Between C and F (C) At C (D) At F
8. A boy is standing in front of a plane mirror at a distance of 3 m from it. What is the distance between the boy and his image ?
- (A) 3 m (B) 4.5 m (C) 6 m (D) none of these

SUBJECTIVE DPP -2.2

1. An object is placed in front of a concave mirror of radius of curvature 15 cm at a distance of (a) 10 cm and (b) 5 cm. Find the position, nature and magnification of the image in each case.
2. What is the difference between virtual images produced by concave, plane and convex mirrors ?
3. A concave mirror produces three times magnified real image of an object placed at 10 cm in front of it. Where is the image located ?



➤➤➤ LIGHT ◀◀◀

PL - 3

3.1 REFRACTION OF LIGHT :

When light travels in the same homogeneous medium it travels along a straight path. However, when it passes from one transparent medium to another, the direction of its path changes at the interface of the two media. This is called refraction of light.

The phenomenon of the change in the path of the light as it passes from one transparent medium to another is called refraction of light. The path along which the light travels in the first medium is called incident ray and that in the second medium is called refracted ray. The angles which the incident ray and the refracted ray make with the normal at the surface of separation are called angle of incidence (i) and angle of refraction (r) respectively.

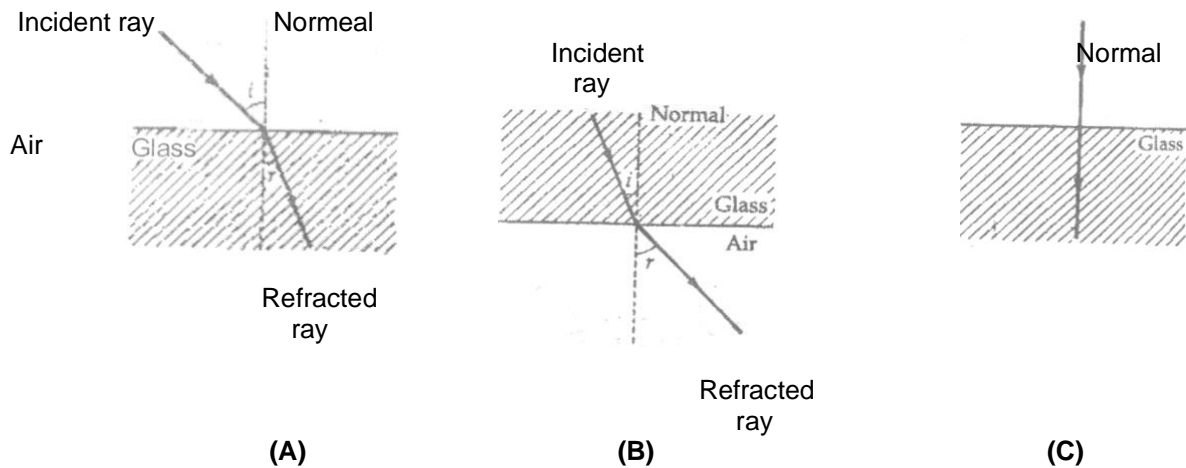

Showing different cases of refraction

It is observed that :

(i) When a ray of light passes from an optically rarer medium to a denser medium it bends towards the normal ($\angle r < \angle i$), as shown in figure (A).

(ii) When a ray of light passes from an optically denser to a rarer medium it bends away from the normal ($\angle r > \angle i$) as shown in figure (B).

(iii) A ray of light traveling along the normal passes undeflected, as shown in figure (C). Here $\angle i = \angle r = 0^\circ$.

3.1 (a) Cause of Refraction :

We come across many media like air, glass, water etc. A medium is a transparent material through which light is transmitted. Every transparent medium has a property known as optical density. The optical density of a transparent medium is closely related to the speed of light in the medium. If the optical density of a transparent medium is low, then speed of light in that medium is high. Such a medium is known as optically rarer medium. Thus, optically rarer medium is that medium through which light travels fast. In other words, a medium in which speed of light is more is known as optically rarer medium.

On the other hand, if the optical density of transparent medium is high, then the speed of light in that medium is low. Such a medium is known as optically denser medium. Thus, optically denser medium is that medium through which light travels slow. In other words, a medium in which speed of light is less is known as optically denser medium.

Speed of light in air is more than the speed of light in water, so air is optically rarer medium as compared to the water. In other words, water is optically denser medium as compared to air. Similarly, speed of light in water is more than the speed of light in glass, so water is optically rarer medium as compared to the glass. In other words, glass is optically denser medium as compared to water.

When light goes from air (optically rarer medium) to glass (optically denser medium) such that the light in air makes an angle with the normal to the interface separating air and glass, then it bends from its original direction of propagation. Similarly, if light goes from glass to air, again it bends from its original direction of propagation. The phenomena of bending of light from its path is known as refraction. We have seen that the speed of light in different media is different, so we can say that refraction of light takes place because the speed of light is different in different media. Thus, **the cause of refraction** can be summarised as follows :

NOTE :

- (i) Refraction is the deviation of light when it crosses the boundary between two different media (of different optical densities) and there is a change in both wavelength and speed of light.
- (ii) The frequency of the refracted ray remains unchanged.
- (iii) The intensity of the refracted ray is less than that of the incident ray. It is because there is partial reflection and absorption of light at the interface.

3.1 (b) Effects of refraction of Light :

- (i) If a straight stick is partially put in water, it appears to be inclined.
- (ii) If we see a water tank its bottom appears to be raised. It also appears to be concave shaped although it is flat.
- (iii) The sun is visible a few minutes earlier than it actually rises above horizon, because as we go up from earth, the density of air layer decreases, then rays from sun keep on bending towards normal till it enters the eye.

∴ Sun appears to be at S'. For the same reason it keeps on appearing two minutes after sun-set. Hence the day i.e. the time between the sunrise & sunset is four minutes longer. The day therefore gets longer 4 minutes.

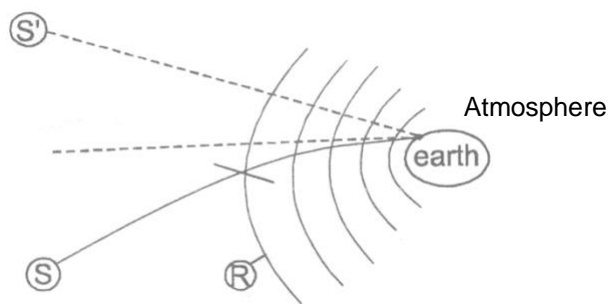

(iv) Twinkling of stars :

On a clear night, you might have observed the twinkling of a star, which is due to an atmospheric refraction of star light. The density of the atmosphere, as we know goes on decreasing as the distance above the sea level increase. For the sake of simplicity, air can be supposed to be made up of a very large number of layers show density decrease with the distance above the surface of the earth. Therefore, the light from a heavenly body, such as a star, goes on gradually bending towards normal as it travels through the earth's atmosphere. As the object is always seen in the direction of the light reaching the observer's eye, the star appears higher up in the sky than its actual position. Further, the densities of the various layers go on varying due to the convection current set up in air by temperature differences. Thus, the refractive index of layer of air at a particular level goes on changing.

Due to these variations in the refractive indices of the various layers of air, the light from a star passing through the atmospheric air changes its path from time to time and therefore, the amount of light reaching the eye is not always the same. This increase or decrease in the intensity of light reaching the eye results in the change in apparent position or twinkling of the star.

3.1 (c) Laws of Refraction :

There are two laws of refraction.

(i) The incident ray, the refracted ray and the normal at the point of incidence lie in the same plane.

(ii) $\frac{\sin i}{\sin r} = \text{constant}$ called refractive index denoted by ' μ '

The above law is called Snell's law (Willebrord Snell). Eg. $\frac{\sin i}{\sin r} = {}_1\mu_2$

Here ${}_1\mu_2$ is called refractive index of 2nd medium w.r.t 1st medium.

{ Law of refraction are valid for both types of surfaces i.e. for plane as well as spherical refracting surfaces. }

3.2 REFRACTIVE INDEX :

3.2 (a) Refractive Index in terms of Speed of Light :

The refractive index of a medium may be defined in terms of the speed of light as follows :

The refractive index of a medium for a light of given wavelength may be defined as the ratio of the speed of light in vacuum to its speed in that medium.

$$\text{Refractive index} = \frac{\text{Speed of light in vacuum}}{\text{Speed of light in medium}}$$

or
$$\mu = \frac{c}{v}$$

Refractive index of medium with respect to vacuum is also called absolute refractive index.

3.2 (b) Refractive Index in terms of Wavelength :

Since the frequency (ν) remain unchanged when light passed from one medium to another, therefore,

$$\mu = \frac{c}{v} = \frac{\lambda_{\text{vac}} \times \nu}{\lambda_{\text{med}} \times \nu} = \frac{\lambda_{\text{vac}}}{\lambda_{\text{med}}}$$

The refractive index of a medium may be defined as the ratio of wavelength of light in vacuum to its wavelength in that medium.

3.2 (c) Relative Refractive Index :

The relative refractive index of medium 2 with respect to medium 1 is defined as the ratio of speed of light

(v_1) in the medium 1 to the speed of light (v_2) in medium 2 and is denoted by ${}_1\mu_2$.

$$\text{Thus, } {}_1\mu_2 = \frac{v_1}{v_2} = \frac{\lambda_1}{\lambda_2} = \frac{\mu_2}{\mu_1}$$

As refractive index is the ratio of two similar physical quantities, so it has no **unit and dimension**.

Factors
on which the refractive index of a medium depends are

- (i) Nature of the medium.
- (ii) Wavelength of the light used.
- (iii) Temperature.
- (iv) Nature of the surrounding medium

It may be noted that refractive index is a characteristic of the pair of the media and also depends on the

wavelength of light, but is independent of the angle of incidence.

Physical significance of refractive Index :

The refractive index of a medium gives the following two information's :

- (i) The value of refractive index gives information about the direction of bending of refracted ray. It tells whether the ray will bend towards or away from the normal.
- (ii) The refractive index of a medium is related to the speed of light. It is the ratio of the speed of light in vacuum to that in the given medium. For example, refractive index of glass is $3/2$. This indicates that the ratio of the speed of light in glass to that in vacuum is $2 : 3$ or the speed of light in glass is two-third of its speed in vacuum.

3.2 (d) Refractive Index in terms of apparent depth and real depth :

Whenever we observe the bottom of a swimming pool or a tank of clear water, we find that the bottom appears to be raised i.e. the apparent depth is less as compared to its real depth. The extent to which the bottom appears to be raised depends upon the value of refractive index of the refracting medium.

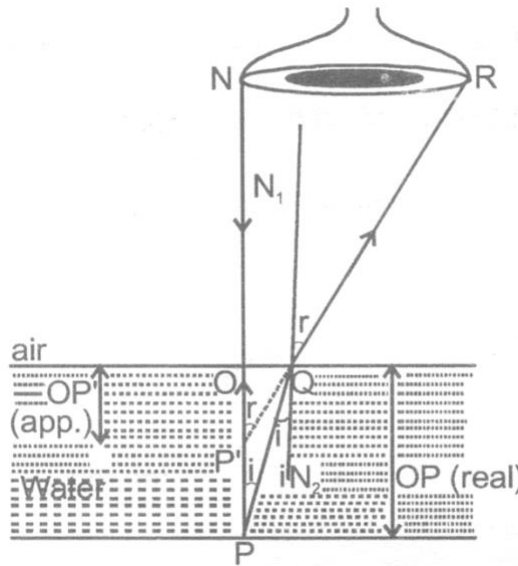

In above fig. $\angle PQN_2 = \angle i$ & $\angle N_1QR = \angle r$

$$\therefore \mu_a = \frac{\sin i}{\sin r}$$

$$\text{Or } \mu_w = \frac{\sin r}{\sin i} \quad \dots\dots\dots(1)$$

As $\angle N_1QR = \angle OP'Q = \angle r$ (corresponding angles)

$$\text{In } \triangle OP'Q \sin r = \angle OP'Q = \frac{OQ}{P'Q} \quad \dots\dots\dots(2)$$

And $\angle i = \angle PQN_2 = \angle QPO$ (alt. Int. ($\angle s$))

$$\therefore \text{In } \triangle QOP \sin i = \sin \angle OPQ = \frac{OQ}{PQ} \quad \dots\dots\dots(3)$$

So from (1) using (2) & (3)

$$a\mu_w = \frac{OQ/P'Q}{OQ/PQ} = \frac{PQ}{P'Q} \quad \dots\dots\dots(4)$$

nearly normal direction of viewing angle i is very small

$$PQ \cong PO$$

$$\& P'Q \cong P'O$$

\therefore from (4)

$$a\mu_w = \frac{PO}{P'O} \Rightarrow a\mu_w = \frac{\text{Real depth}}{\text{Apparent depth}}$$

3.2 (e) Refraction and Speed of Light :

The refraction of light occurs because light has different speed in different media. Speed of light is maximum in vacuum or air. It is less in any other medium. Denser in the medium lesser is the speed of light. Refractive index of a medium depends not only on its nature and physical conditions, but also on the colour or wavelength of light. It is more for violet light and less for red light (VIBGYOR). To find refractive index of two media w.r.t. each other when their refractive indices w.r.t. air are given. A ray of light AB refracts from different medium as shown in figure below.

(i) For refractive index at interface A'B'

$${}_a\mu_w = \frac{\sin x}{\sin y} \quad \dots\dots\dots(i)$$

(ii) For refractive index at interface C'D'

$${}_a\mu_g = \frac{\sin y}{\sin z} \quad \dots\dots\dots(ii)$$

(iii) For refractive index at interface E'F'

$${}_g\mu_a = \frac{\sin z}{\sin x} \quad \dots\dots\dots(iii)$$

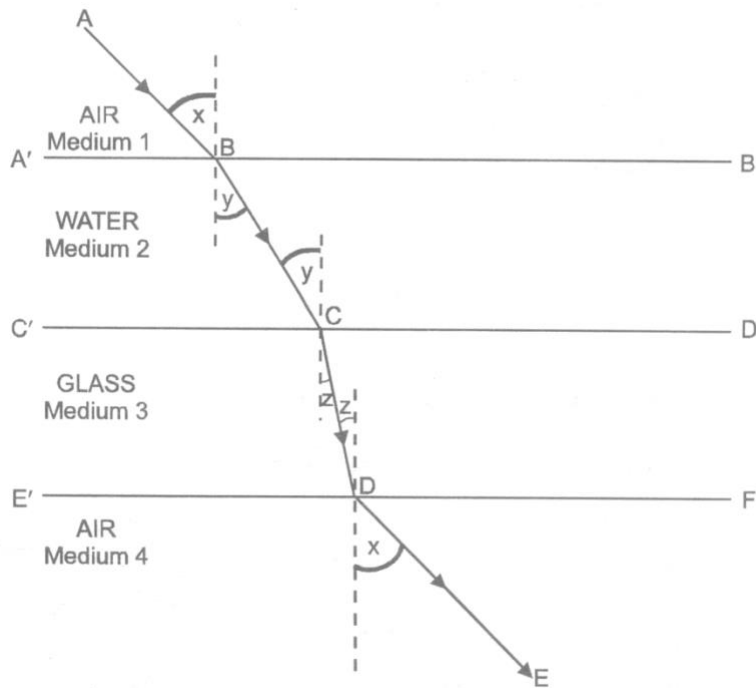

Multiply (1), (2) & (3)

$${}_a\mu_w \times {}_a\mu_g \times {}_g\mu_a = 1$$

$${}_g\mu_a = \frac{1}{{}_a\mu_w \times {}_a\mu_g}$$

$${}_w\mu_g = \frac{{}_a\mu_g}{{}_a\mu_w} \dots\dots\dots(iv) \quad \left(\text{as } \frac{1}{{}_g\mu_a} = {}_a\mu_g \right)$$

and on reciprocal

$${}_g\mu_w = \frac{{}_a\mu_w}{{}_a\mu_g} \dots\dots\dots(v)$$

∴ In general we can write as

$${}_2\mu_3 = \frac{{}_1\mu_3}{{}_1\mu_2}$$

$${}_3\mu_2 = \frac{{}_1\mu_2}{{}_1\mu_3}$$

Illustration :

Calculate the speed and wavelength of light (i) in glass & (ii) in air, when light waves of frequency 6×10^{14} Hz. travel from air to glass of $\mu = 1.5$.

Sol. Here $\nu = 6 \times 10^{14}$ Hz. $\mu = 1.5$

(i) In glass speed of light $V_g = \frac{V_a}{\mu} = \frac{3 \times 10^8}{1.5} = 2 \times 10^8 \text{ m/s}$

Wavelength of light $\lambda_g = \frac{V_g}{\nu} = \frac{2 \times 10^8}{6 \times 10^{14}} = 3.3 \times 10^{-7} \text{ m.}$

(ii) In air speed of light $V_a = 3 \times 10^8 \text{ m/s}$

Wavelength of light $\lambda_a = \frac{V_a}{\nu} = \frac{3 \times 10^8}{6 \times 10^{14}} = 5 \times 10^{-7} \text{ m.}$

3.3 REFRACTIN THROUGH GLASS SLAB :

3.3 (a) Refraction through a rectangular glass slab :

Consider a rectangular glass slab, as shown in figure. A ray AE is incident on the face PQ at an angle of incidence i . on entering the glass slab, it bends towards normal and travels along EF at an angle of refraction r . The refracted ray EF is incident on face SR at an angle of incidence r' . The emergent ray FD bends away from the normal at an angle of refraction e . Thus the emergent ray FD is parallel to the incident ray AR, but it has been laterally displaced with respect to the incident ray. There is shift in the path of light on emerging from a refracting medium with parallel faces.

Lateral shift :

Lateral shift is the perpendicular distance between the incident and emergent rays when light is incident obliquely on a refracting slab with parallel faces.

Factors on which lateral shift depends are :

- (i) Lateral shift is directly proportional to the thickness of glass slab.
- (ii) Lateral shift is directly proportional to the incident angle.
- (iii) Lateral shift is directly proportional to the refractive index of glass slab.
- (iv) Lateral shift is inversely proportional to the wavelength of incident light.

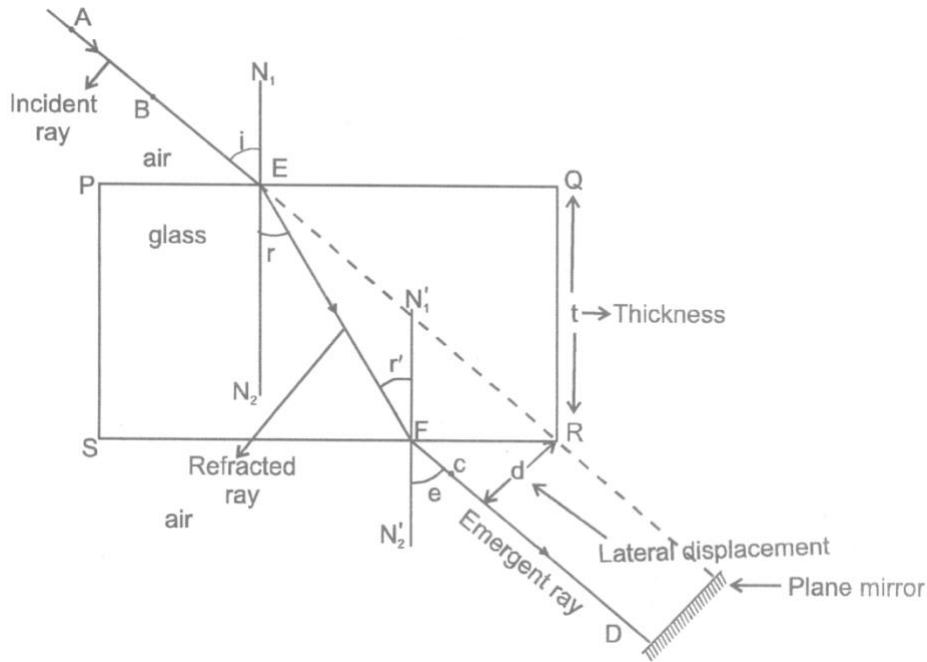

Figure : :Lateral shifting of light in glass slab

If a plane mirror is placed in the path of emergent ray FD then the path of the emergent ray along FD is reversed back, it follows the same path along which it was incident i.e. the incidence ray becomes the emergent ray & emergent ray becomes the incident ray. It is known as principle of reversibility of light.

Case - I : For light going from air to glass of point E.

$\angle i$ = angle of incident, $\angle r$ angle of refraction.

$${}_a\mu_g = \frac{\sin i}{\sin r} \quad \dots\dots\dots(1) \quad ({}_a\mu_g = \text{absolute refractive index of glass})$$

Case - II : For light going from glass to air at point F.

$$\Rightarrow {}_g\mu_a = \frac{\sin r}{\sin e} \quad \text{where } \left\{ \begin{array}{l} \angle r = \text{angle incidence} \\ \angle e = \text{angle of refraction} \end{array} \right\} \therefore \angle r = \angle e$$

$$\Rightarrow {}_g\mu_a = \frac{\sin r}{\sin i} \quad (\text{as } \angle e = \angle i)$$

$$\therefore \frac{1}{{}_g\mu_a} = \frac{\sin i}{\sin r} \quad \dots\dots\dots(2)$$

∴ From (1) & (2)

$${}_a\mu_g = \frac{1}{{}_g\mu_a} \quad \Rightarrow \quad [{}_a\mu_g \times {}_g\mu_a = 1]$$

DAILY PRACTICE PROBLEMS # 3

OBJECTIVE DPP - 3.1

1. R.I. of glass w.r.t. air is $\frac{3}{2}$, then the R.I. of air w.r.t. glass is -
(A) $\frac{3}{4}$ (B) $\frac{2}{3}$ (C) $\frac{1}{3}$ (D) 3
2. Refractive index of glass with respect to air is 1.5 and refractive index of water with respect to air is $\frac{4}{3}$. What will be the refractive index of glass with respect to water ?
(A) 1 (B) 1.5 (C) 1.125 (D) -10
3. The refractive index of a medium depends upon -
(A) Nature of material of the medium
(B) Optical density of the medium
(C) Wavelength of light
(D) All of these
4. If refractive index of water w.r.t. air is $\frac{4}{3}$, then refractive index of air w.r.t. water will be -
(A) 4×3 (B) $\frac{3}{4}$ (C) $\sqrt{\frac{4}{3}}$ (D) $\sqrt{\frac{3}{4}}$
5. A ray of light is incident normally on a rectangular piece of glass. The value of angle of refraction will be -
(A) 180° (B) 90° (C) 45° (D) 0°
6. A fish looking up through the water sees the outside world contained in a circular horizon. If the refractive index of water is $\frac{4}{3}$ and the fish is 12 cm below the surface, the radius of the circle is -
(A) $12 \times 3 \times \sqrt{5}$ cm (B) $12 \times 3 \times \sqrt{7}$ cm (C) $12 \times \sqrt{5/2}$ cm (D) $12 \times \frac{3}{\sqrt{7}}$ cm
7. The speed of light in vacuum is 3.0×10^8 m/s. If the refractive index of a transparent liquid is $\frac{4}{3}$, then the speed of light in the liquid is -
(A) 2.25×10^8 m/s (B) 3×10^8 m/s (C) 4×10^8 m/s (D) 4.33×10^8 m/s
8. A swimming pool appears to be 2m deep. Its actual depth is (μ for water = 1.33)-
(A) 2.66 m (B) 2m (C) 2.34 m (D) 2.54 m

SUBJECTIVE DPP - 3.2

1. When light of two colour A and B is passed through a plane boundary, A is bent more than B. Which colour travel slowly in the second medium ?
2. What is the effect on the wavelength of light when it travel from rarer to denser medium ?
3. Light enters from air to glass having refractive index 1.5. What is the speed of light in glass ?
4. Light of wavelength 500 nm in air enters a glass plate of refractive index 1.5 find :
 - (a) Speed in glass.
 - (b) Frequency in glass.
 - (c) Wavelength of light in glass.



➤➤➤ LIGHT ◀◀◀

PL - 4

4.1 SPHERICAL LENSES :

A lens is a piece of transparent refracting material bounded by two spherical surface or one spherical and other plane surface.

A lens is the most important optical component used in microscopes, telescopes, cameras, projectors etc.

Basically lenses are of two types :

- (i) Convex lens or converging lens
- (ii) Concave lens or diverging lens

4.1 (a) Convex lens and its type :

A lens which is thick at the centre and thin at the edges is called a convex lens. The most common form of a convex lens has both the surfaces bulging out to the middle. Some forms of convex lens are shown in the figure.

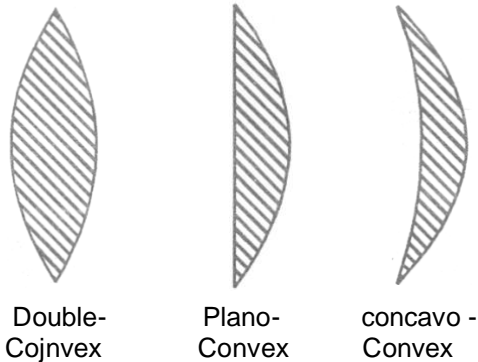

4.1 (b) Concave lens and its type :

A lens which is thin at the middle and thick at the edges is called a concave lens. The most common form of a concave lens has both the surfaces depressed inward at the middle. Some forms of concave lenses are shown in the figure.

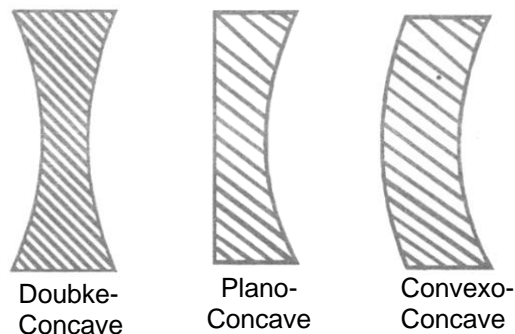

Figure : Different types of concave lens

4.1 (c) Definitions in connection with spherical lens :

(i) Centre of curvature (C) :

The centre of curvature of the surface of lens is the centre of the sphere of which it forms a part, because a lens has two surfaces, so it has two centers of curvature. In figure (a) & (b) points C_1 & C_2 are the centers of curvature.

(ii) Radius of curvature (R) :

The radius of curvature of the surface of a lens is the radius of the sphere of which the surface forms a part. R_1 & R_2 in the figure (a) & (b) represents radius of curvature.

(iii) Principle axis ($C_1 C_2$) :

It is the line passing through the two centers of curvature (C_1 & C_2) of the lens.

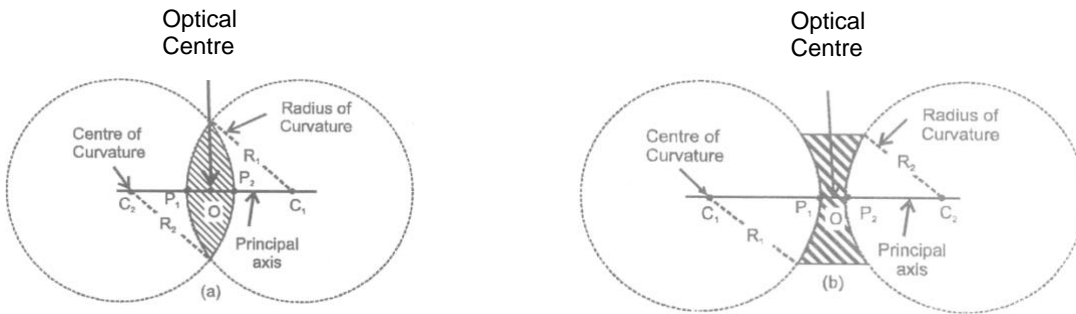

Figure : Characteristics of convex and concave lenses

(iv) Optical centre :

If a ray of light is incident on a lens such that after refraction through the lens the emergent ray is parallel to the incident ray, then the point at which the refracted ray intersects the principal axis is called the optical centre of the lens. In the figure O is the optical centre of the lens. It divides the thickness of the lens in the ratio of the radii of curvature of its two surfaces. Thus :

$$\frac{OP_1}{OP_2} = \frac{P_1C_1}{P_2C_2} = \frac{R_1}{R_2}$$

If the radii of curvature of the two surfaces are equal, then the optical centre coincides with the geometric centre of the lens.

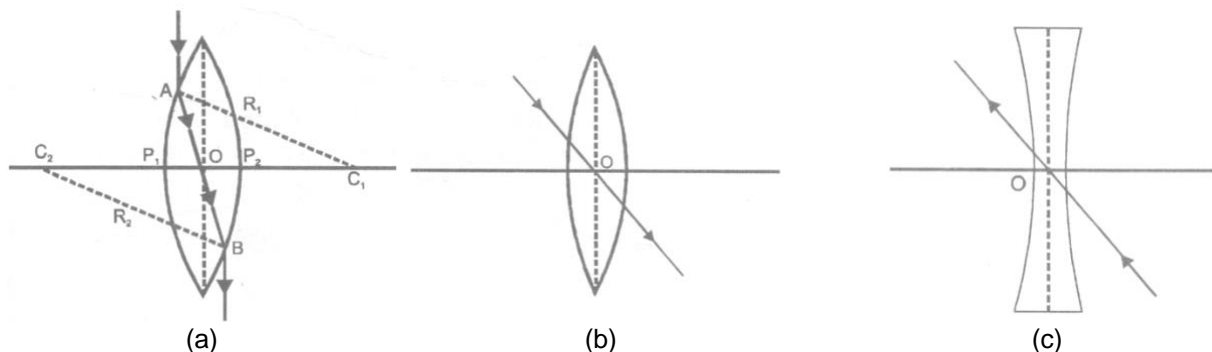

Figure : Ray diavram Showing lateral displacement

For a ray passing through the optical centre, the incident and emergent rays are parallel. However, the emergent ray suffers some lateral displacement relative the incident ray. The lateral displacement decrease with the decrease in thickness of the lens. Hence a ray passing through the optical centre of a thin lens does into suffer any lateral deviation, as shown in the figure (b & (c) above.

(v) Principal foci and focal length :

(A) First principal focus :

It is fixed point on the principal axis such that rays starting from this point (in convex lens) or appearing to go towards this point (concave lens), after refraction through the lens, become parallel to the principal axis. It is represented by F_1 or F' . The plane passing through this point and perpendicular to the principal axis is called the first focal plane. The distance between first principal focus and the optical centre is called the first focal length. It is denoted by f_1 or f' .



Figure : Ray diagram showing First principal focus

(B) Second principal focus :

It is a fixed point on the principal axis such that the light rays incident parallel to the principal axis, after refraction through the lens, either converge to this point (in convex lens) or appear to diverge from this point (in concave lens). The plane passing through this point and perpendicular to principal axis is called the second focal plane. The distance between the second principal focus and the optical centre is called the second focal length. It is denoted by f_2 or f .

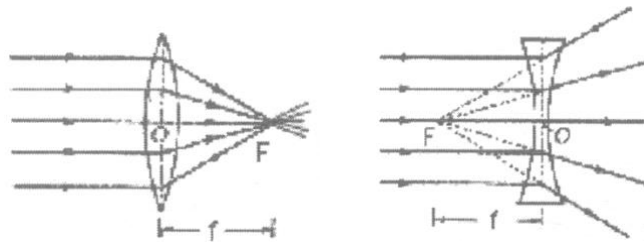

Figure : Ray diavram showing second principal focus

Generally, the focal length of a lens refers to its second focal length. It is obvious from the above figures, that the foci of a convex lens are real and those of a concave lens are virtual. Thus the focal length of a convex lens is taken positive and the focal length of a concave lens is taken negative.

If the medium on both sides of a lens is same, then the numerical values of the first and second focal length are equal. Thus

$$f = f'$$

(vi) Aperture :

It is the diameter of the circular boundary of the lens.

4.2 CONVEX LENS :

4.2 (a) Rules for the formation of images by Convex Lens :

The positions of the image formed by a convex lens can be found by considering two of the following rays (as explained below).

(i) A ray of light coming parallel to principal axis, after refraction through the lens, passes through the principal focus (F) as shown in the figure.

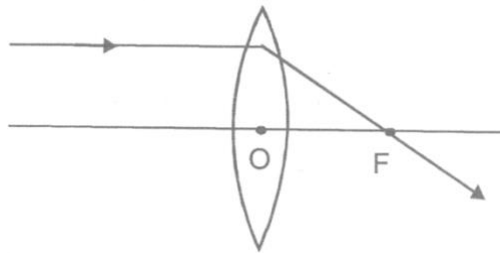
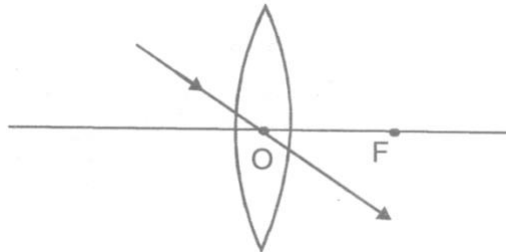
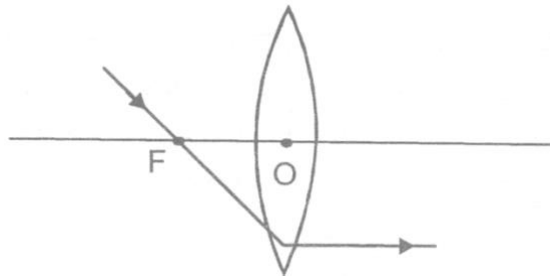

Figure : Convex Lens

(ii) A ray of light passing through the optical centre O of the lens goes straight without suffering any deviation as shown in the figure.



(iii) A ray of light coming from the object and passing through the principal focus of the lens after refraction through the lens, becomes parallel to the principal axis.



4.2 (b) Image formed by Convex Lens :

The position, size and nature of the image formed by a convex lens depends upon the distance of the object from the optical centre of the lens. For a thin convex lens, the various case of image formation are explained below :

(i) When object at infinity :

When an object lies at infinity, the rays of light coming from the object may be regarded as a parallel beam of light. The ray of light BO passing through the optical centre O goes straight without any deviation. Another parallel ray AE coming from the object, after refraction, goes along EA'. Both the refracted rays meet at A' in the focal plane of the lens. Hence, a real, inverted and highly diminished image is formed on the other side of the lens in its focal plane.

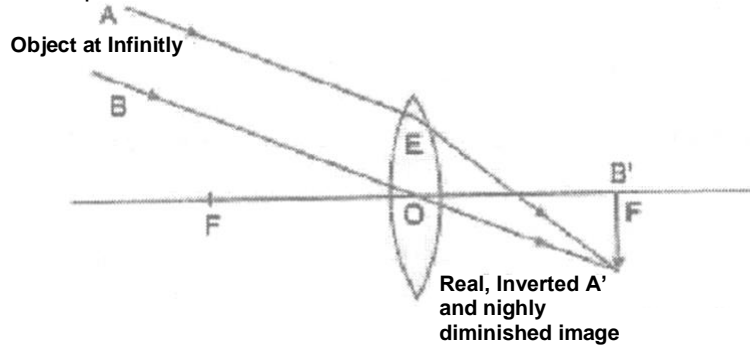

(ii) When object lies beyond 2F :

When an object lies beyond 2F, its real, invert and diminished image is formed between F and 2F on the other side of the lens as explained below :

A ray of light AE coming parallel to the principal axis, after refraction, passes through the principal focus F and goes along EF. Another ray AO passing through the optical centre O goes straight without suffering any deviation. Both the refracted rays meet at A'. Hence a real, inverted and diminished image is formed between F and 2F on the other side of the convex lens.

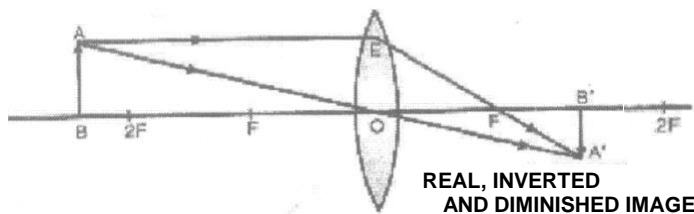

(iii) When object lies at 2F :

When an object lies at 2F, its real, inverted image having same size as that of the object is formed on the other side of the convex lens as explained below :

A ray of light AE coming parallel to the principal axis, after refraction, passes through the principal focus F and goes along EF, Another ray AO passing through the optical centre O goes straight without suffering any deviation. Both the refracted rays meet at A'. Hence a real, inverted image having the same size as the of the object is formed at 2F on the other side of the lens.

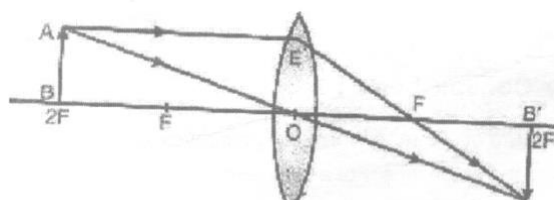

(iv) When object lies between F and 2F.

When an object lies between F and 2F in front of a convex lens, it real, inverted and magnified image is formed beyond 2F on the other side of the lens an explained below :

A ray of light AE coming parallel to the principal axis, after refraction, passes through the principal focus F and goes along EF . Another ray of light AO passing through the optical centre goes straight without any deviation. Both these refracted rays meet at A' . Hence a real, inverted and magnified image is formed beyond $2F$ on the other side of the lens.

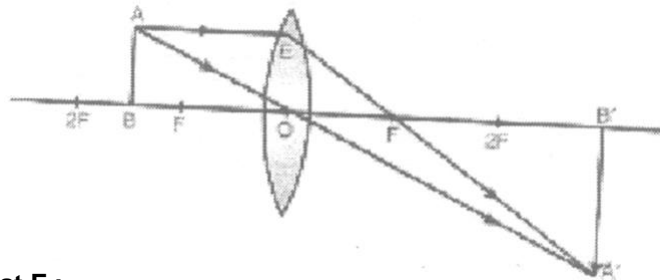

(v) When object lies at F :

When an object lies at the principal focus F of a convex lens, then its real, inverted and highly magnified image is formed at infinity on the other side of the lens as explained below :

A ray of light AE coming parallel to the principal axis, after refraction, passes through the principal focus F and goes along EF . Another ray of light AO passing through the optical centre O goes straight without any deviation. Both these refracted rays are parallel to each other and meet at infinity. Hence a real, inverted, highly magnified image is formed at infinity on the other side of the lens.

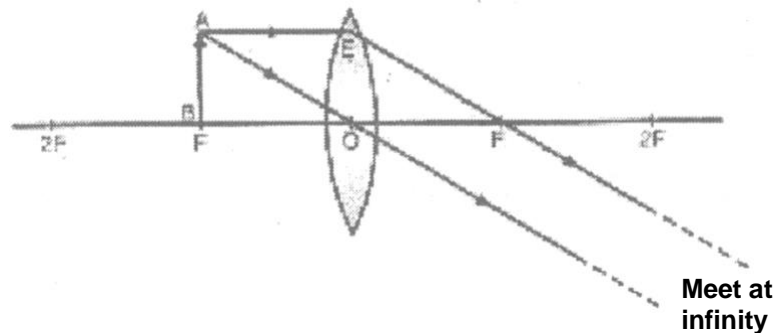

(vi) When object lies between O and F :

When an object lies between the optical centre O and the principal focus F of a convex lens, then its virtual, erect and magnified image is formed on the same side as that of the object as explained below :

A ray of light AE coming parallel to the principal axis, after refraction, passes through the principal focus F and goes along EF . Another ray of light AO passing through the optical centre goes straight without any deviation. Both these refracted rays appear to meet at A' . When produced backward. Hence virtual, erect and enlarged image is obtained on the same side of the lens.

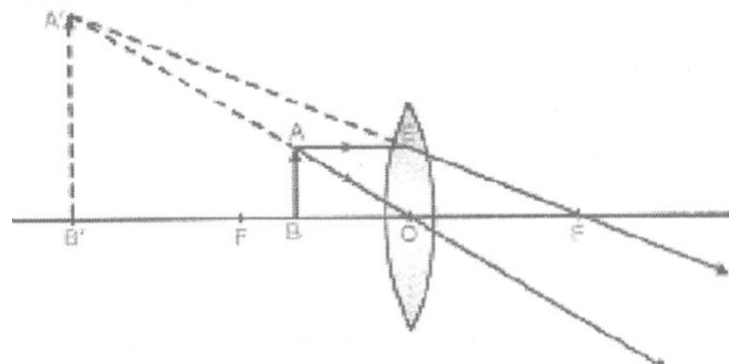

The results of image formation by a convex lens are summarised in the table:

Position of the object	Position of the image	Size of the image	Nature of the image
At infinity	At the focus F	Highly diminished	Real and inverted
Beyond 2F	Between F and 2F	Diminished	Real and inverted
At 2F	At 2F	Same size	Real and inverted
Between F and 2F	Beyond 2F	Magnified	Real and inverted
At F	At infinity	Highly magnified	Real and inverted
Between O and F	On the side of the object	Magnified	Virtual and erect

4.3 CONCAVE LENS

4.3 (a) Rules for the formation of images by Concave Lens :

The position of the image formed by a concave lens can be found by considering following two rays coming from a point object (as explained below).

- (i) A ray of light coming parallel to the principal axis, after refraction, appears to pass through the principal focus F of the lens, when produced backward as shown in figure (a).
- (ii) A ray of light passing through the optical centre O of the lens goes straight without suffering any deviation as shown in figure (b).

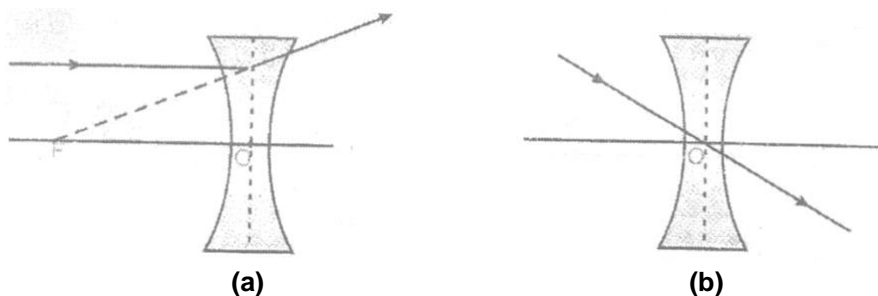

4.3 (b) Image formed by Concave Lens :

The image formed by a concave lens is always virtual, erect and diminished and is formed between the optical center O and the principal focus F of the lens. For a thin concave lens of small aperture, the cases of image formation are discussed below.

(i) When the object lies at infinity :

When an object lies at infinity in front of a concave lens, a virtual, erect, highly diminished image is formed at the principal focus F as explained below.

The rays of light AE and BD coming parallel to the principal axis of the concave lens, after refraction, go along EG and DH respectively. When extended in the back direction, these refracted rays appear to pass through the principal focus F. Hence a virtual, erect and highly diminished image is formed at the principal focus F.

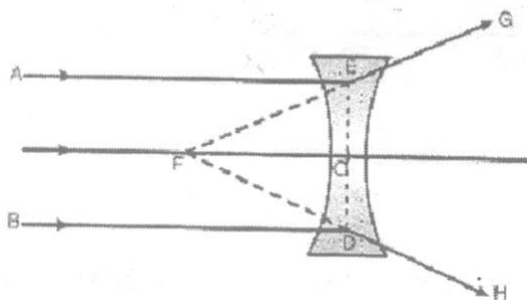

(ii) When the object lies between 0 and ∞ :

When an object lies at any position between the optical center O and infinity in front of a concave lens, the image formed is virtual, erect, diminished and is formed between the optical centre O and the principal focus F as explained below.

A ray of light AE coming parallel to the principal axis, after refraction, goes along EG and appears to pass through principal focus when produced backward and another ray which is passing through the optical centre O goes straight without any deviation. Both these refracted rays appear to meet at A'. hence, a virtual erect, diminished image is formed between O and F.

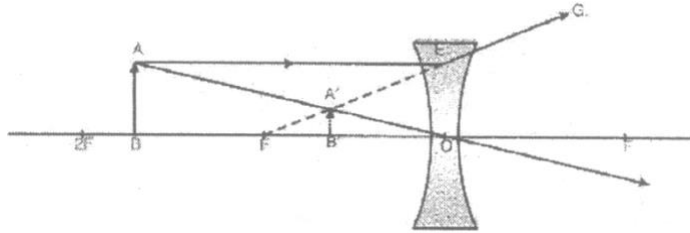

The summary of image formation by a concave lens for different positions of the object is given in table.

Position of the object	Position of the image	Size of the image	Nature of the image
At infinity	At F	Highly diminished	Virtual and erect
Between O and ∞	Between O and F	Diminished	Virtual and erect

4.4 POWER OF A LENS :

It is the measure of deviation produced by a lens. It is defined as the reciprocal of its focal length in metres.

Its unit is Dioptre (D) (f should always be in metres).

$$\text{Power (P)} = \frac{1}{\text{focal length (f in m)}}$$

Power of a convex lens is +ve (As it has a real focus and its focal length measured is +ve.)

Power of a concave lens is -ve (As it has a virtual focus and its focal length measured is -ve.)

NOTE :

(i) If two lenses are placed in contact, the combination has a power equal to the algebraic sum of the

$$\text{powers of two lenses, } P = P_1 + P_2 \Rightarrow \frac{1}{f} = \frac{1}{f_1} + \frac{1}{f_2}.$$

(ii) If two thin lenses are placed at d distance, then the combination has a power equal to-

$$P = P_1 + P_2 - dP_1P_2 \Rightarrow \frac{1}{f} = \frac{1}{f_1} + \frac{1}{f_2} - \frac{d}{f_1f_2}.$$

Here, f_1 and f_2 are the focal length of lenses and f is focal length of combination of lenses.

4.5 LENS FORMULA :

Relation between object distance u , image distance v and focal length f is : $\frac{1}{v} - \frac{1}{u} = \frac{1}{f}$.

4.6 LINEAR MAGNIFICATION :

Linear magnification (m) is defined as the ratio of the size of the image to the size of the object.

$$m = \frac{A'B'}{AB} = \frac{h_2}{h_1} = \frac{\text{height of image}}{\text{height of object}}, \quad \text{also } m = \frac{v}{u}$$

if m is +ve (image is virtual & erect).

if m is -ve (image is real & inverted)

DAILY PRACTICE PROBLEMS # 4

OBJECTIVE DPP - 4.1

- To get a real and inverted image of the same size as that the object should be placed in front of the convex lens at:
(A) F (B) 2F
(C) between F and 2F (D) away from 2F, where F is focal length
- A spherical mirror and a spherical lens have each focal length of - 10cm. The mirror and lens are :
(A) both convex (B) both concave
(C) mirror is convex and lens is concave (D) mirror is concave and lens is convex
- The power of lens having focal length 50 cm is :
(A) $\frac{1}{2}$ D (B) 2D (C) 3D (D) 0.2 D
- The focal length of a lens of power - 2.0 D is :
(A) -2.0 m (B) 0.2 m (C) 0.5 m (D) 0.5 m
- Two lenses of +5D and -5D are placed in chose contact. The focal length of the combination is :
(A) Zero (B) ∞ (C) Zero or ∞ (D) None of these
- A student needs a lens of power -2.0 dioptrre to correct his distant vision. The focal length of the given lens is :
(A) + 50 cm (B) -50 cm (C) 10 cm (D) -10 cm
- Focal length of coloured goggles (without number) i :
(A) zero (B) infinity
(C) between zero & infinity (D) None of these
- Where should an object be placed so that a real and inverted image of very large size is obtained, using a convex lens ?

- (A) At the focus (B) At $2F$ (C) Between F & $2F$ (D) Beyond $2F$
9. A convex lens is :
 (A) Thicker at the middle, thinner at the edges
 (B) Diverging
 (C) Thicker at the edges thinner in the middle
 (D) Of uniform thickness everywhere
10. A glass rod of refractive index 1.42 is immersed in kerosene. The refractive index of kerosene is 1.42. Then the rod will :
 (A) appear bent (B) appear raised above the liquid
 (C) become invisible (D) none of the above
11. The power of a lens whose focal length is 25 cm is :
 (A) 4 Dioptre (B) 25 Dioptre (C) 0.04 Dioptre (D) 2.5 Dioptre
12. A thin lens is made with a material having refractive index $\mu = 1.5$. Both the side are convex. It is dipped in water ($\mu = 1.33$), it will be have like :
 (A) a convergent lens (B) a divergent lens
 (C) a rectangular slab (D) a prism
13. Choose the correct option :
 (A) If the final rays are converging, we have a real image.
 (B) If the incident rays are converging, we have a real image.
 (C) If the image is virtual, the corresponding object is called a virtual object.
 (D) The image of a virtual object is called a virtual image.
14. A convex lens forms a real image of a point object placed on its principal axis. If the upper half on the lens is painted black :
 (A) the image will be shifted backward
 (B) the image will not be shifted
 (C) the intensity of the image will decrease
 (D) both (B) & (C)
15. The minimum distance between an object and its real image formed by a convex lens of focal length f is :
 (A) f (B) $2f$ (C) $3f$ (D) $4f$

SUBJECTIVE DPP - 4.2

1. A convex lens forms a real and inverted image of a needle at a distance of 50 cm from the lens. Where should the needle be placed in front of the convex lens so that this image is of the same size as the object. Also find the power of lens.
2. It is possible for a lens to act as a convergent lens in one medium and a divergent lens in another
3. What is the power of a concave lens of focal length 50 cm ?
4. Two lenses of power + 3.5 D and -2.5 D are placed in contact. Find the power and focal length of the lens combination